

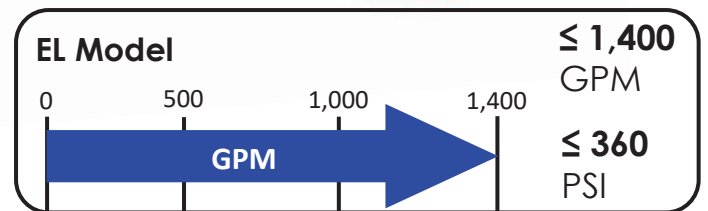

EL MODEL

MXQ Progressive Cavity Pumps



CHARACTERISTICS

- Close coupled version of EH Model
- 100% Bornemann Equivalent
- Wide range of applications
- Smooth & continuous flow
- Low pulsation
- Capacities up to 1,400 GPM
- Differential pressures up to 360 PSI
- Can pass solids up to 3"

MATERIALS OF CONSTRUCTION

Casing	GG-25, 1.4408, 1.4571, 1.4462
Rotor	C45 Hard Chrome, 1.4571, 1.4462
Shaft	1.4021, 1.4571, 1.4462
Stator	SBR, NBR, HNBR, FKM, IIR, CSM, EPDM

PUMP DESCRIPTION

The EL model is one of the best progressive cavity pumps on the market. There are many standard features that set it apart from the competition, such as:

- ⇒ Cardan Style Universal Joints
- ⇒ Elongated Profile
- ⇒ SS Internal Shafting & Hardware
- ⇒ Bronze Lantern Packing Ring
- ⇒ Access Ports on Suction Casing
- ⇒ Stuffing Box Flush Connections
- ⇒ Pressure Gauge Fittings





EL MODEL

Pump Performance By Model

Model	RPM*	1 stage=90psi (GPM)	2 stage=180 psi (GPM)	4 stage=360 psi (GPM)
EL 164	100	1.5	.75	.30
EL 236	100	3	1.5	.75
EL 375	100	6	3	1.5
EL 600	100	12	6	3.0
EL 1024	100	24	12	6.0
EL 1500	100	50	24	12.5
EL 1900	100	100	50	25
EL 2650	100	150	75	37.5
EL 4500	100	250	125	62.5
EL 6300	100	350	175	87.5

*Maximum operating speed is 400 RPM

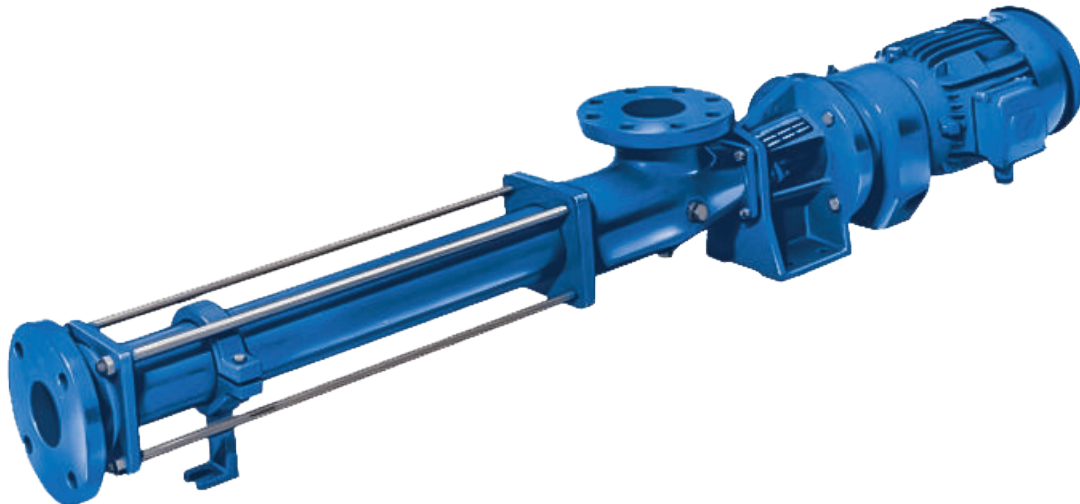



Cardan Joint Exploded View - Sizes B, C, D, E

MXQ EH Progressive Cavity Pumps

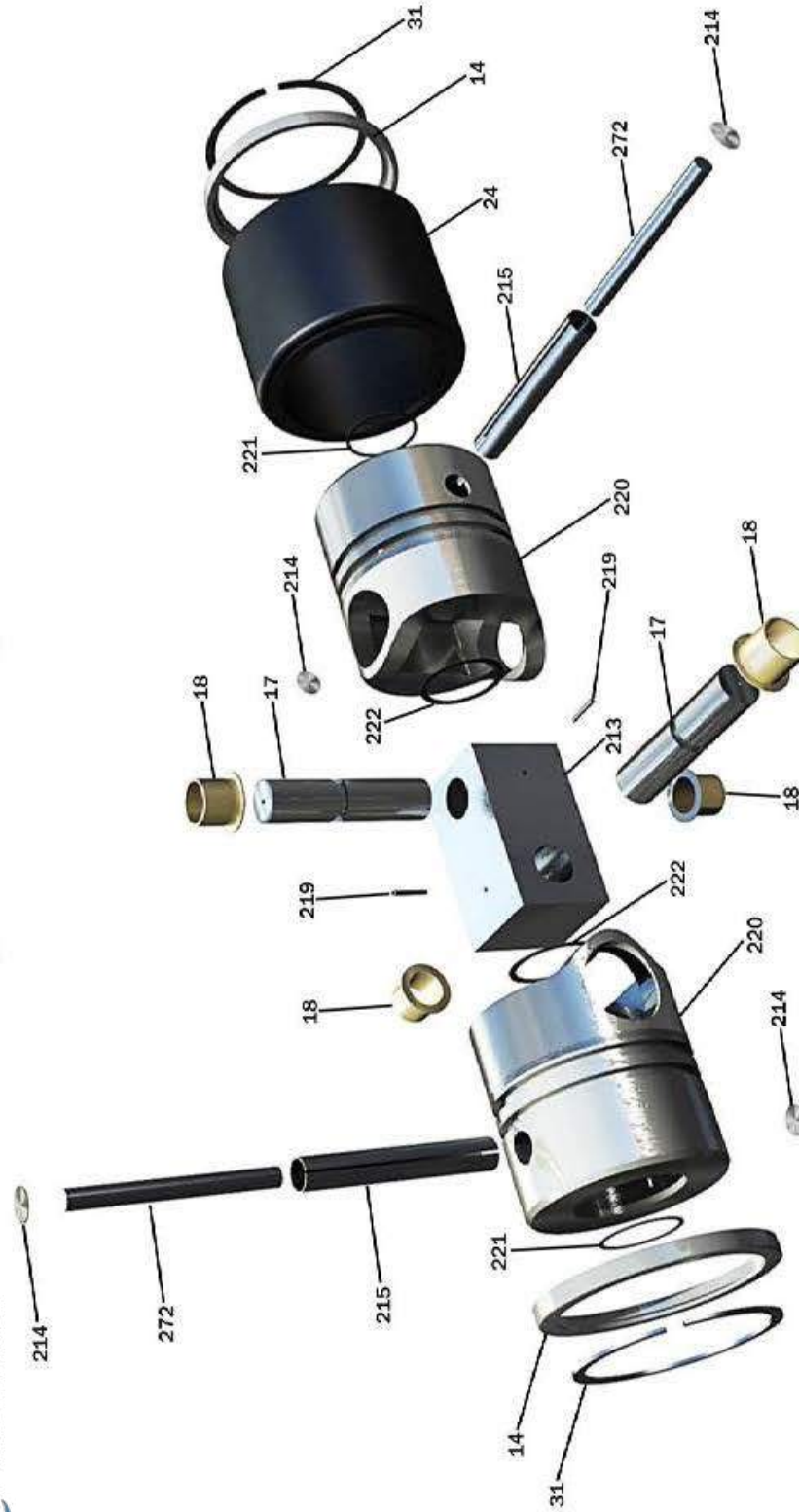

<u>Item</u>	<u>Qty.</u>	<u>Description</u>	<u>Item</u>	<u>Qty.</u>	<u>Description</u>
14	2	Boot Collar	215	2	Sleeve
17	2	Joint Pin	219	2	Locking Pin
18	4	Joint Bushing	220	2	Joint Head
24	1	Boot Cover	221	2	Shaft O-ring
31	2	Boot Collar Snap Ring	222	2	Joint O-ring
213	1	Block Pulley (Yoke)	272	2	Taper Pin
214	4	Sealing Disc	501	1	Complete Assembly